

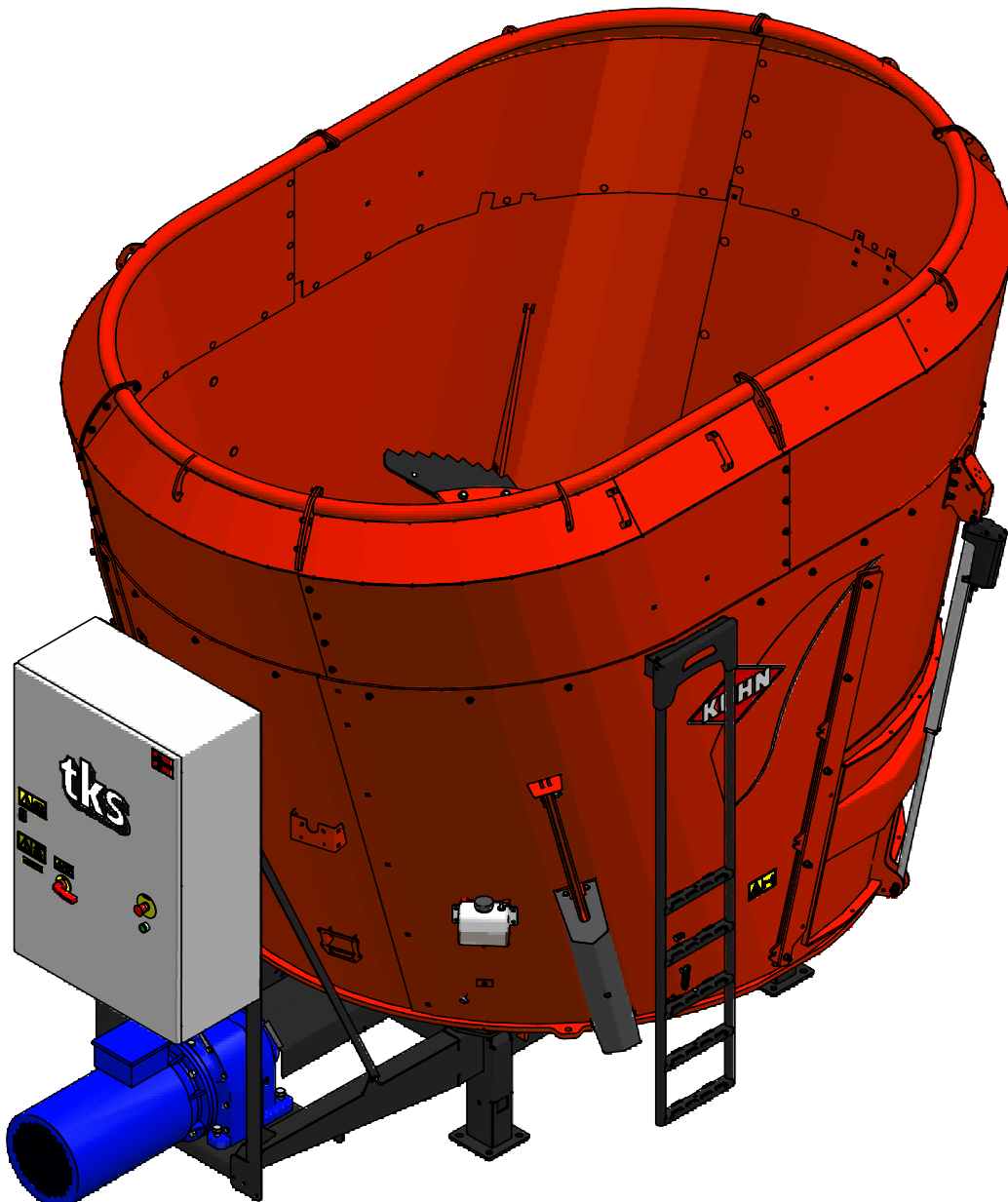

User's manual TKS Controller

Program version: FM2.0.0



Content

1 GENERAL SAFETY INSTRUCTIONS	4
2 USING THE SCREEN AND PLC	12
3 OPERATION	14
4 TROUBLESHOOTING	33
1 General safety instructions	4
1.1 CE - Declaration of conformity.....	4
1.2 Guarantee	5
1.3 Introduction	6
1.4 Machine identification	7
1.5 Safety	8
1.5.1 General safety instruction.....	8
1.5.2 Additional safety instructions	10
1.5.3 The control cabinet must be secured with padlock.....	11
2 Using the screen and PLC	12
2.1 Screen.....	12
2.2 Additional equipment: Wi-Fi box for remote control.....	12
2.3 Numeric keypad.....	13
2.4 Selecting a value.....	13
2.5 On / off key	13

3 Operation	14
3.1 Activate FeedMixer	14
3.2 Menus	14
3.2.1 Home	14
3.2.2 Perform a mixing operation	15
3.2.3 Perform a feedout operation	15
3.2.4 Settings	16
3.2.5 Manual control	16
3.2.6 Recipe filling	18
3.3 Settings	21
3.3.1 Settings for mixing	21
3.3.2 Settings for feedout	22
3.3.3 Settings for activation	23
3.3.4 Settings for filling sources	24
3.3.5 Automatic filling with schedule	25
3.3.6 Automatic filling with weight	25
3.3.7 Settings options	26
3.3.8 Door settings	27
3.3.9 Weight settings	28
3.3.10 Maintenance / Energy	29
3.3.11 Feedout timer	30
3.3.12 Language	30
3.4 Alarms	31
3.5 Doors 2 and 3 (Option)	32
4 Troubleshooting	33
Notes	34

1 General safety instructions

1.1 CE - Declaration of conformity

We,
TKS Agri AS,
Kvernelandsvegen 100
N-4355 Kverneland
Norway
declare that the product:

TKS Kuhn - FeedMixer has been built in conformity with the Machine Directive and meets the relevant fundamental health and safety requirements.

Kverneland, 15 April 2023

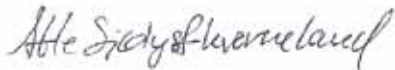

Atle Sjølyst - Kverneland
General Manager

**Enter the serial number
of the machine here :**

TKS Agri AS, manufacturer of agricultural products, reserves the right to change the design and/ or specification of its products without prior warning. This does not imply any obligation to modify previously supplied machines.

1.2 Guarantee

This TKS product is guaranteed against manufacturing and material defects for one year.

If the owner wishes a defect to be covered by the product guarantee, he or his representative must inform the dealer of this when ordering parts and/ or repairs. Claims must be reported within the guarantee period.

The dealer must complete a claims form for each case covered by a guarantee and send it to TKS or TKS's distributor/ importer within the 10th of the month following the one in which the defect was reported.

The defective parts shall be marked with the claim number and be kept for up to 6 months so that TKS or TKS's distributor/ importer can inspect them.

Since TKS products are used outside the manufacturer's control, we can only guarantee the product quality, and not that it will perform its function, nor are we liable for any consequential damage.

The guarantee is not valid if:

- a) third party spare parts are used, or the product is repaired or altered without the approval of TKS
- b) the operating and servicing instructions have not been followed.
- c) the machine has been used for other purposes than those for which it is designed.

The guarantee does not cover damage due to normal wear and tear.

Official safety regulations specify requirements that apply to the users/ owners and manufacturers of this machine, relating to the careful review of safety hazards that may arise when this type of machine is used correctly. Therefore, TKS and our importer/ distributor are not responsible for the functioning of components that are not shown in the spare parts catalogue for this product.

TKS reserves the right to change the design of the product without this implying any obligations in relation to previously supplied machines.

NB! It must be possible to identify all enquiries relating to this product by the product's serial number; see page 7 on Machine identification.

1.3 Introduction

Congratulations on buying your new TKS product. You have chosen a functional, high quality product. A network of helpful dealers will be able to advise you on its use, as well as provide servicing and spare parts.

All TKS products are designed, tested and built in close cooperation with farmers and machine workshops to ensure optimal efficiency and reliability.

Please read this instruction manual carefully and familiarise yourself with the machine's manner of operation before starting to use it. There are many conditions and variables that can affect the machine's functionality and manner of operation. It is therefore vital that you consider all known conditions and adapt usage according to these. A good understanding of the machine's manner of operation and performance, together with a high degree of knowledge with regard to feeding and feed types/consistencies will ensure the best possible result. The machine is a highly advanced feed robot that operates without the need for supervision and must be used in accordance with the applicable instructions from the manufacturer and other regulations in force at any given time.

By being thorough and making the necessary adaptations to local conditions, you will ensure the best possible results.

Yours faithfully
TKS Agri AS

tks

**TKS Agri AS,
Kvernelandsvegen 100
N-4355 Kverneland
Norway**

**www.tks-agri.no
e-post: post@tk-as.no
Phone: + 47 51 77 05 00**

1.4 Machine identification

The machine's serial number and the address of the manufacturer are written on the machine. See the illustration on this page.

Please use the information on the name plate when making any enquiries about spare parts or servicing.

This product is CE marked. This mark, along with the associated written EU confirmation, means that the product fulfils current health and safety requirements, and complies with the following directives.

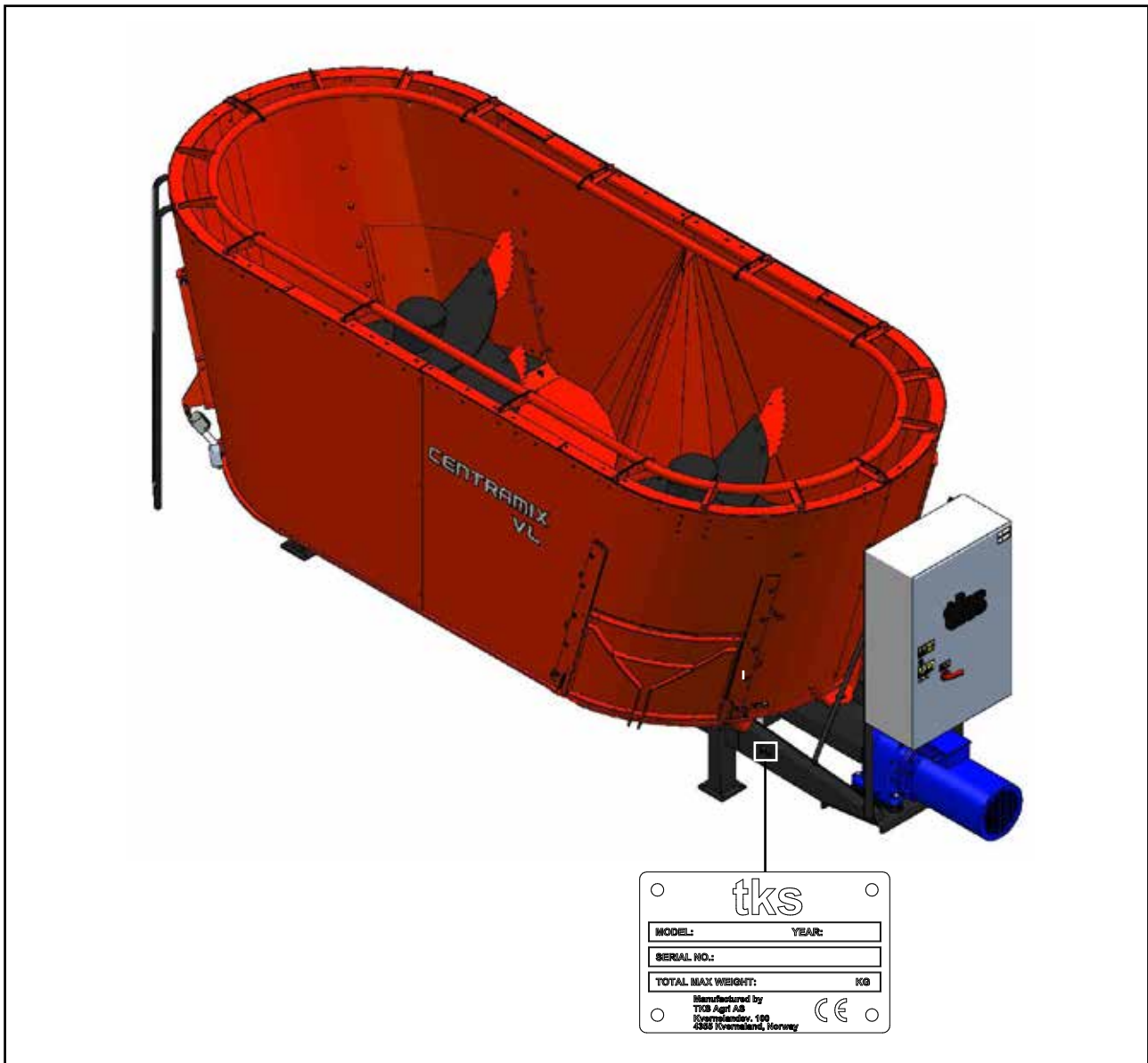

1.5 Safety



Please pay particular attention to this symbol. It designates a safety risk, and describes precautions that must be taken to avoid accidents. The control cabinet must be powered off and locked with padlock when maintenance is performed.

Before operating, adjusting or repairing the machine, the user, technician or owner should familiarise himself with the safety instructions contained in this installation manual.

Pay attention and be careful when handling agricultural machinery. Read and take note of the safety instructions in this manual.

Safety at work is your responsibility!



Please read and understand these general safety instructions.

1.5.1 General safety instructions

In order to be able to load the bale into the hopper, the machine must be open.

This means that people may come into contact with moving parts if they are standing in the immediate vicinity of the machine while it is in use.

Warning! Once the auger is running, never lean over the top edge of FeedMixer or enter the hopper when the machine is operating.

If the machine is placed in a sunken floor, the distance from the floor to the top of FeedMixer must not be less than 1.5 m.

It is a conditional requirement of using the machine that no one must be in the immediate vicinity of the machine during use.

In addition, in terms of machine type, FeedMixer is of conventional agricultural design and, from a safety perspective, the solutions chosen are considered to be on a par with or superior to existing products on the market.

Use of the machine

The machine must only be used for the purpose for which it is designed.

Operating

The machine operator must remain at the end of the machine where the control box and the associated operating panel are mounted.

Supervision

The owner/operator must ensure that the area is sufficiently signposted and that there is no unauthorised access.

Automation

The machine is equipped with devices to automate the entire operation or select parts of the operation for this purpose. The machine can operate based on a preset schedule set in the software by the operator, and start at certain times without human presence.

The area in which the machine is operating

Must be physically sealed off or locked to prevent danger to humans or animals.

The machine's method of operation

The operator must familiarise himself with the machine's method of operation and function so that the machine can be used in a safe and appropriate manner.

Keep a safe distance

Humans and animals must be kept away from the machine when it is in operation. Keep your distance from working, rotating and moving parts.

Think safety at work

Never climb on the machine while it is operating. When performing maintenance, the power supply must be disconnected

Warning – audio and illuminated indicator

The control system (software) has been updated for safe start-up. A built-in buzzer sounds for 30 seconds before start-up of the machine. This audio signal is accompanied by a light signal that flashes during the entire period of operation.

Protective guards

Check that all guards are in place and installed correctly. Do not start the machine until this has been done. Damaged guards must be repaired or replaced immediately.

Spare parts

For safety reasons we recommend that you only use original spare parts. The use of third-party spares invalidates the product guarantee.

Maintenance

Ensure that the machine is properly maintained and is kept in good condition. Never attempt to change the mechanical workings of the machine.

Control panel

The power supply must be cut off before opening the panel.

1.5.2 Additional safety instructions

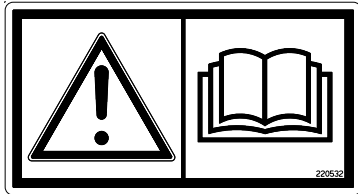

Fig. 1

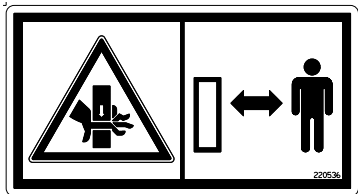

Fig. 2

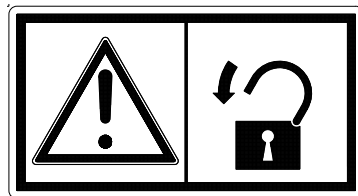

Fig. 3

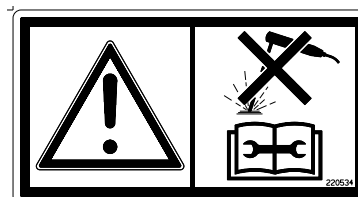



Fig. 4

The machine is marked with a  warning signs. If these signs are damaged, they must be replaced.

Warning sign UH220532 (Fig. 1)

Be careful! Ensure that you read and understand the instruction manual before using the machine, and before making any adjustments or performing any maintenance.

Warning sign UH220536 (Fig. 2)

Risk of crushing hand.
Keep away from the counter knives.

Warning sign 988346 (Fig. 3)

The main power switch must be secured by a padlock.

Work should only be performed by authorised personnel.

Warning sign UH220534 (Fig. 4)

Disconnect all electrical connections before carrying out welding work or maintenance.

1.5.3 The control cabinet must be secured with padlock

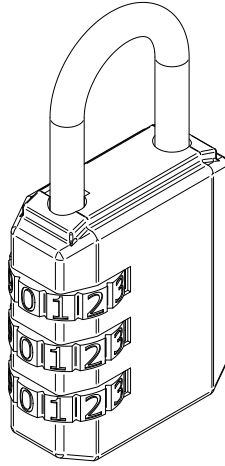

Picture 1

Important!

The control cabinet must be powered off and locked with padlock when maintenance is performed, especially when knives are sharpened or being replaced. The padlock can be found inside the control cabinet.

Enter your personal code:

1. Set the three code pads so that 0-0-0 is set in the middle of the arrow marker on the short edge of the padlock and raise the handlebar.
2. Turn the hoop 90 degrees counterclockwise and push it down as far as it goes.
3. While holding the hoop down, enter your personal code using the three code discs.
4. Release the hoop and turn it back to its original position.

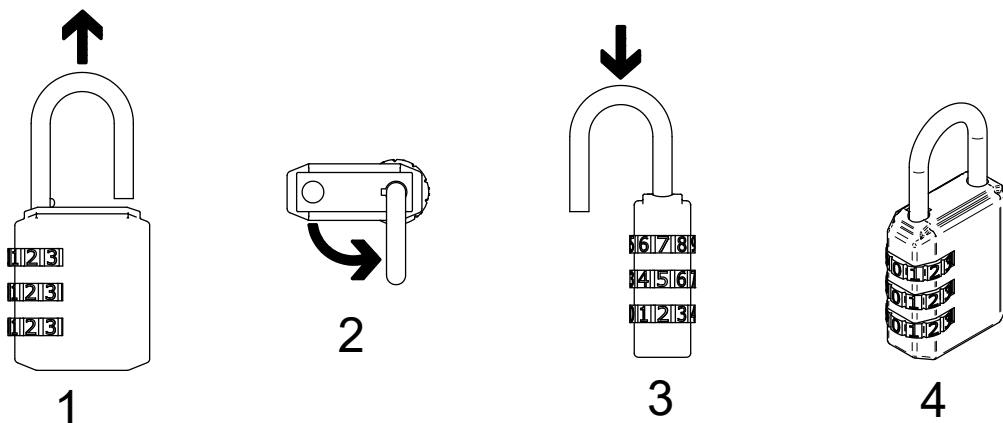

Picture 2

NB! The padlock are now ready for use with your personal code.

2 Using the screen and PLC

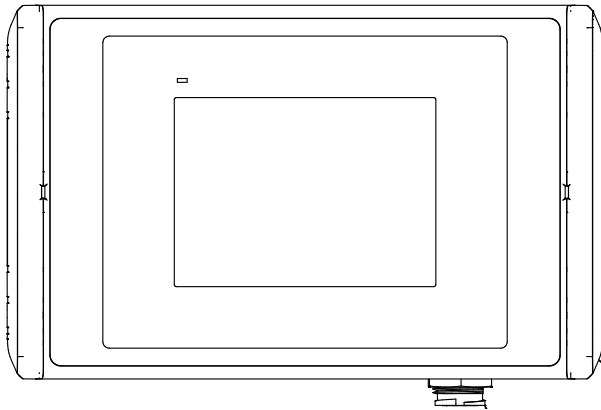

Picture 3



Picture 4

2.1 Screen

The control box is attached to the machine with magnets. It is connected to the machine using the included PoE-T cable, which is plugged in between the box and the controller. This is a standard Ethernet cable, but with a protective cover over the connectors.

IMPORTANT! This is **NOT** a standard Ethernet port as found on the screen and controller. The cable also carries power, so **ONLY TKS PoE-T** equipment should be connected here.

The control system features a touchscreen. You can tap it with your finger or use a special stylus, but only one touch at a time. Avoid pressing too hard, as this can damage the screen. If the screen has been inactive for a few minutes, it will enter screensaver mode and appear off. Tap anywhere on the screen to activate it again.

Note! The screen should be cleaned with a damp cloth.

2.2 Additional equipment: Wi-Fi box for remote control.

IMPORTANT!

It is crucial to verify the model of the machine's control cabinet. The control system **MUST** be version 1.9.0 or higher. **Note!** This is **NOT** standard Ethernet used in the cable. **ONLY TKS** equipment should be connected here.

On the underside of the cabinet, you will find the Ethernet socket/port to which the display is connected.

- This cable is removed and connected to one of the ports (**A**) on the Wi-Fi box.
- Next, take the additional cable included in the Wi-Fi box set and plug it into the other port (**B**) on the Wi-Fi box. Refer to image 4.
- The other end of the cable is plugged into the now vacant port in the control system.
- The Wi-Fi box comes with pre-installed magnetic brackets, making it easy to attach to the machine.

NOTE!

- Wi-Fi signals require clear line of sight for optimal performance, so the box should be mounted high on the machine.
- Once the control system is installed, the machine can be accessed via a mobile phone, tablet, or PC.



Picture 5



Picture 6

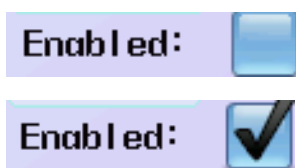

Picture 7

2.3 Numeric keypad

Values in fields with blue borders can be changed. Touch the number and a numeric keypad will display on the screen.

The top of the screen shows the Max/Min value that can be entered in this field.

Enter a new value using the number keys. If an incorrect value was entered, press the <- key and delete the most recently entered number. Press **CLR** to delete everything.

To enter a negative value, press - before entering the value.

Once you have selected a value, press the **ENTER** button.

This will save the value and close the keypad window.

To cancel, press **X** in the upper right-hand corner. The old value will continue to be active.

To enter times in the feedout schedule window, begin by entering the hours – then press period. Then enter the minutes. Make sure that the time is right.

For example, if you enter 12:65, this will be ignored – enter 13:05 instead.

2.4 Selecting a value

Selecting pre-programmed values from a list.

- Open the list – Press the value or the down arrow
- Select a value from the list

2.5 On / off key

Enable or disable a function using the on/off key.

- Unchecked means off, disabled
- A checkmark means on, enabled

3 Operation

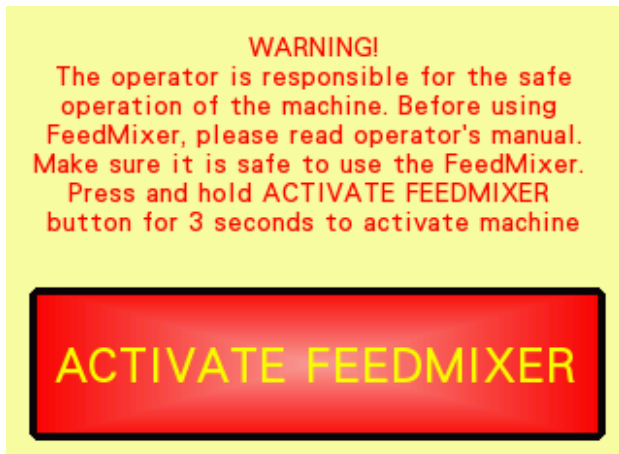

Picture 8

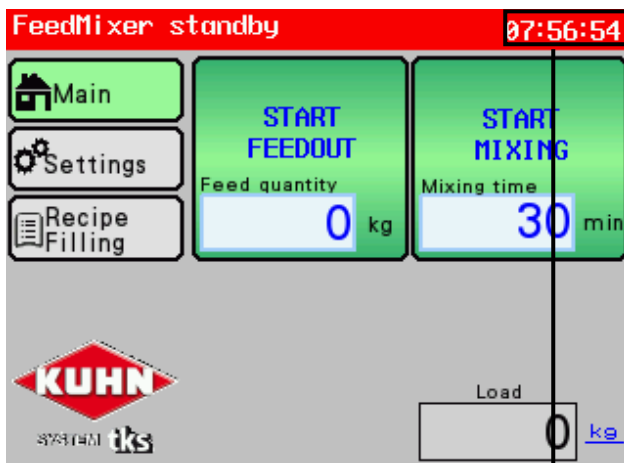

Picture 9

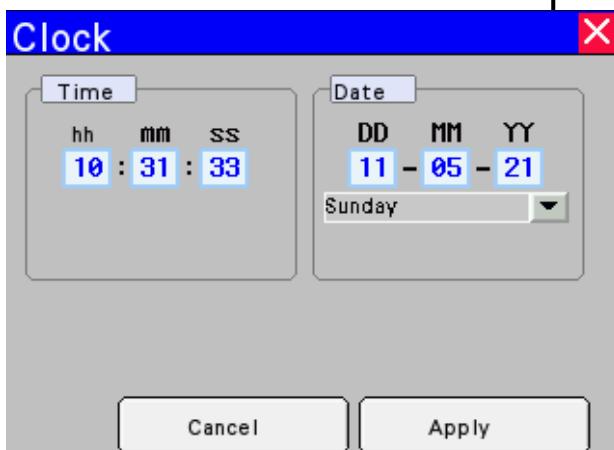

Picture 10

3.1 Activate FeedMixer

When FEEDMIXER is switched on, or when the emergency stop button is pressed, screen picture will display.

Read the instructions on the screen and make sure that the machine can be used properly. Release the emergency stop button if it has been tripped.

Press "**ACTIVATE FEEDMIXER**" and hold it down for three seconds before Home screen appears.

3.2 Menus

3.2.1 Home

When FeedMixer is activated, the Home screen displays. The following displays:

- Menu on the left
- Start keys for mixing and feeding on the right
- The load of the content in the mixer is shown at the bottom
- The current menu selection is indicated by a key highlighted in green
- The red line at the top shows FeedMixer activity
- **AUTO** – shows when the Feedout timer is activated.

Clock settings

Hold on the selected area up in the right corner of the screen for 3 seconds for clock settings.

Time

Hours hh, minutes mm, seconds ss, adjusted individually.

Date

- Day DD, month MM, year YY adjusted individually.
- Day of the week chosen from the list
- Press **Apply** to save

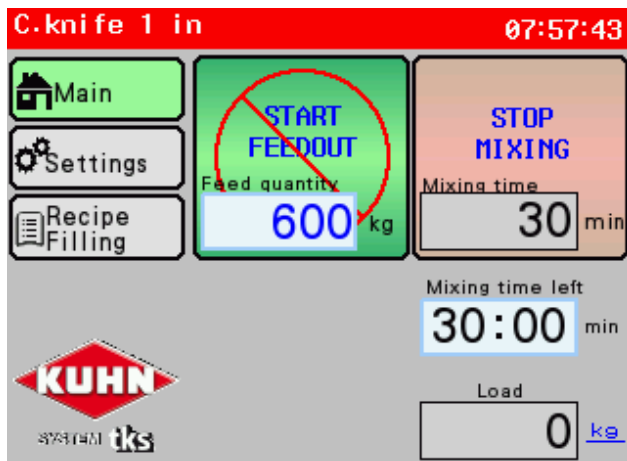

Picture 11

3.2.2 Perform a mixing operation

- Load FeedMixer with feed
- **Feed weight** shows the number of kg loaded
- Adjust desired mixing time
- Tap the number on the **START MIXING** key
- Enter the number of minutes and then press Enter
- Press and hold the **START MIXING** key for 3 seconds
- The motor goes through its start-up sequence and mixing begins

Once mixing has commenced, the **START MIXING** key changes to a red **STOP** key.

Below the keys is a field with a **Mixing time left**. It can be changed if desired.

The **START FEEDOUT** key is locked, but the number of kilograms to be dispensed can be changed. Once mixing is complete, FeedMixer stops on its own and the screen displays two green start keys.

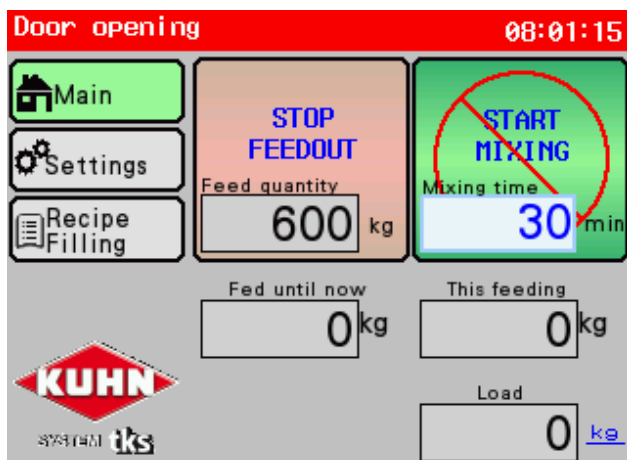

Picture 12

3.2.3 Perform a feedout operation

After mixing, a feedout operation can be started. In the field on the

- **START FEEDOUT** key, enter the **Feedout quantity** in kg.
- Press and hold the **START FEEDOUT** key for three seconds,
- FeedMixer begins the feedout sequence.
- The door opens, the counter knives retreats, the conveyor starts and the feed discharges.

Once the feedout operation has commenced, the **START FEEDOUT** key changes to a red **STOP** key. Two fields display below the keys.

The first field shows the quantity discharged so far in kg, and the second shows the quantity for this feedout session in kg.

The **START MIXING** key is locked, but the **Mixing time** can be changed.

Once the feedout operation is complete, FeedMixer stops on its own and the screen displays two green start keys.

To empty FeedMixer completely, enter 0 kg in **Feedout quantity** before commencing the feedout operation.

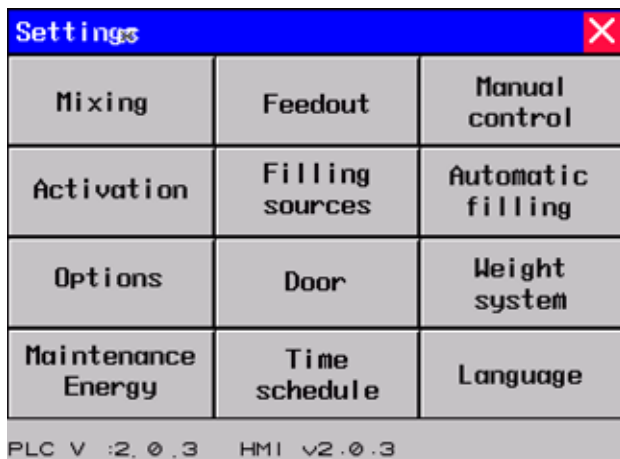

Picture 13

3.2.4 Settings

Open the settings using Settings in the menu. Twelve sub-menus display for FeedMixer settings:

- Mixing – settings for mixing
- Feedout – settings for feedout
- Manual control – control separate functions
- Activation – settings for remote control
- Filling sources – settings for filling sources
- Automatic filling – automatic settings
- Options – settings for the motor and equipment
- Door – door settings
- Weighting system – weight settings
- Maintenance/energy – shows maintenance intervals, hour meters and energy consumption
- Time schedule – schedule for automatic feed dispensing
- Language - select display language

The program version of the PLC is displayed at the bottom: PLC 1.XX and screen: HMI v1.XX

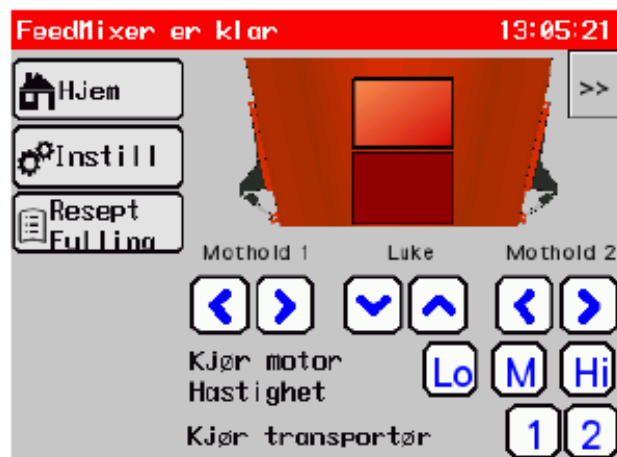

Picture 14

3.2.5 Manual control

Open manual control by touching **Manual** in the menu.

Operation of the door

- Open the door using the up arrow
- Close the door using the down arrow
- The door is operated when the arrow key is pressed, and stops when the arrow key is released
- The arrow key lights up green on activation
- The door stops once the end position is reached
- The door also moves on the screen

Operation of counter knives

- Counter Knife 1 is moved in position using the right arrow key. (Plate 1)
- Counter Knife 1 is retracted using the left arrow key. (Plate 1)
- Counter Knife 2 is moved in position using the left arrow key. (Plate 2)
- Counter Knife 2 is retracted using the right arrow key. (Plate 2)
- The arrow key lights up green on activation
- The counter knives stops once the end position is reached.
- The bedknife also moves on the screen

FeedMixer standby		14:02:40
Main	<<	9. 8 OFF
		10.9 OFF
Settings	1. kraftfor.	11.10 OFF
	2. tst2	12.11 OFF
Recipe Filling	3. ti	13.12 OFF
	4. uy	14.13 OFF
	5. kk	15.14 OFF
	6. 5	16.15 OFF
	7. 6	17.ny 6 OFF
	8. 7	18.ny 7 OFF

Picture 15

Operation of motor

- In manual operation, the motor rotates in the forward direction.
- Start motor at pre-defined speeds
- **Lo** = low speed
- **M** = medium speed
- **Hi** = high speed
- The motor runs for as long as the key is held down, and stops when it is released.
- The key lights up green on activation.

Operation of conveyors

- Two conveyors can be operated individually.
- **1** – operates conveyor 1
- **2** – operates conveyor 2
- The conveyors run for as long as the key is held down, and stop when it is released.

Control of filling sources

- Open separate window using the double chevrons at the top right.
- Displays filling sources 1–18
- Filling sources indicate whether they are manual or automatic (PLC A3:) (**Option**)
- Test drive the filling source by holding in the key

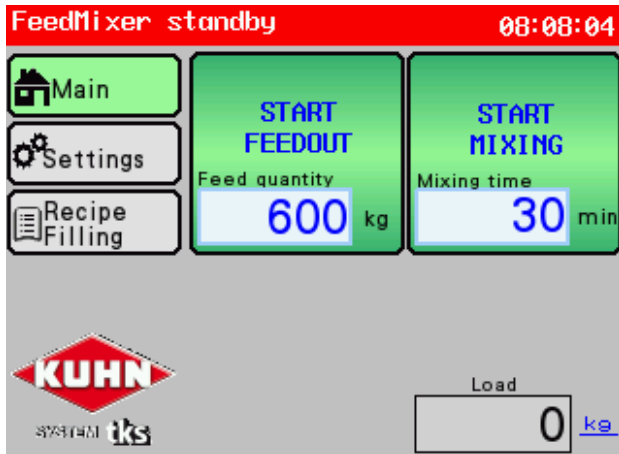

Picture 16

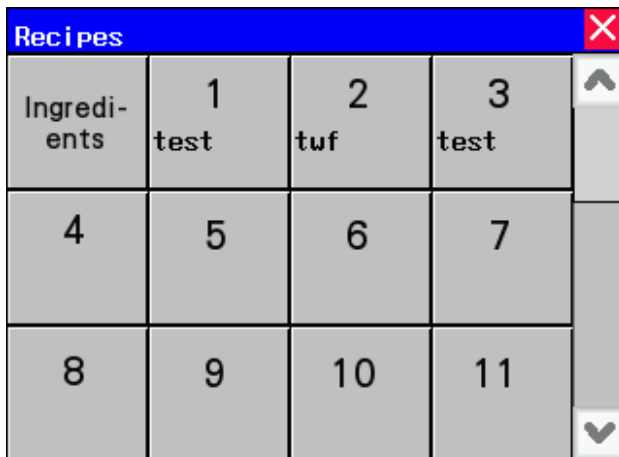

Picture 17

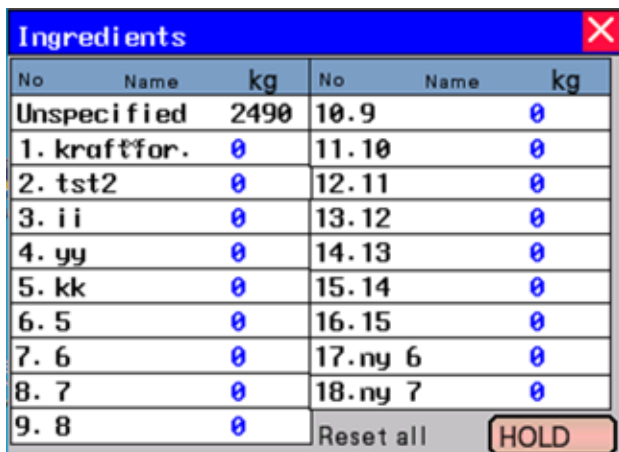

Picture 18

3.2.6 Recipe filling

Open Recipe filling in the menu

Recipe filling can be used manually or automatically.

For manual use, this is a guide to help fill in the correct quantity of each feed component based on weight.

For automatic operation, the connected filling sources start and fill the specified quantity in order from a recipe. For automatic filling, electrical equipment must be installed in the electrical cabinet.

Contact your dealer.

The recipes can consist of both manual and automatic filling sources.

Selection of recipe

This window shows programmed and blank recipes 1–23

The ingredients box shows the content in the container now

Select a recipe.

To create a new recipe, press inside a blank box.

After selection, a new screen will be shown.

To exit without changing, press the red cross.

Ingredients

The window shows the content in the container now. Unspecified consists of feed that is loaded outside automatic filling, or residual feed from previous feed dispensing.

Unspecified loaded feed can be moved to a different ingredient manually.

- Press the blue figure to the desired ingredient
 - Enter the desired amount to be moved
- All ingredients can be removed from the list. The weight of these ingredients will be transferred with unspecified quantity.

Press – Reset all and HOLD for three seconds.

No.	Type	Amount	Mix	ACK
1.	---	0.0 kg	<input type="checkbox"/>	<input type="checkbox"/>
2.	---	0.0 kg	<input type="checkbox"/>	<input type="checkbox"/>
3.	---	0.0 kg	<input type="checkbox"/>	<input type="checkbox"/>
4.	---	0.0 kg	<input type="checkbox"/>	<input type="checkbox"/>
5.	---	0.0 kg	<input type="checkbox"/>	<input type="checkbox"/>
6.	---	0.0 kg	<input type="checkbox"/>	<input type="checkbox"/>

Picture 19

Reci	No.	Type	Amount	ACK
0.	None	10.9		<input type="checkbox"/>
1.	1.kraftfor.	11.10		<input type="checkbox"/>
2.	2.tst2	12.11		<input type="checkbox"/>
3.	3.ii	13.12	×	<input type="checkbox"/>
4.	4.yy	14.13		<input type="checkbox"/>
5.	5.kk	15.14		<input type="checkbox"/>
6.	6.5	16.15		<input type="checkbox"/>
7.	7.6	17.ny 6		<input type="checkbox"/>
8.	8.7	18.ny 7		<input type="checkbox"/>
9.	9.8	19. Mix		<input type="checkbox"/>

Picture 20

Recipe filling

- Write the name of the recipe.
- Enter the types of feed. Press on the fields. Select from the list in the next window. (Programming of filling sources must be done in advance in Menu-> Settings-> Filling sources)
- To remove a ingredients, select 0 None.
- The lightest feed should be filled first. See chapter 3.2 about filling order.
- Intermediate mixing can be added between feed ingredients. Enter number of minutes mixing time.
- Enter the amount
- Switch between kg and %. Press on the unit. When loading bales, it is difficult to achieve an exact number of kg gross feed so it is useful to use % for quantity when filling with grain feed.
- If "Feed in kilograms per animal" is checked (see section 3.3.6), the values can be set to the number of animals. The total weight will then be weight x number of animals.

All recipes can consist of up to 18 ingredients. A specific feed ingredient can be repeated several times to add different layers. For additional lines, press the **Line 7–12** key or the **Line 13–18** key.

- When filling is finished, the mixer can automatically start to mix and cut the feed.
- Enter the appropriate mixing time.
 - Mixing after filling**
- If you do not want automatic mixing, enter 0 min.
- Perform a filling sequence
Press **START FILLING**



Picture 21



Picture 22



Picture 23

Recipe filling in progress

- This window shows the recipe filling in progress.
- The current recipe is shown at the top.
- The status indicator shows in per cent how much of the feed component has been filled.
- The weight of the filling **loaded so far/how much to be loaded is shown underneath**.
- During filling an audible warning will be given when 80% of the weight of the feed component has been achieved.
- The audible signal becomes more intense up to 100%.
- At 95% the indicator changes colour from yellow to green.
- The filling is complete when the sound stops.
- In the event of overloading, the indicator will turn red from 105%
- When filling from a filling source is complete, the indicator changes to the next component in the recipe within 10 seconds (plus any additional pause time).
- It is important that the mixer does not move unnecessarily after the feed component has been loaded. This will result in a longer waiting time before the next component starts.
- When an intermediate mix is in progress, the mixing process is shown in the status window

At the bottom of the screen there are keys to stop the process.

Stop this process

- Stops the ongoing feed component and moves on to the next component in the recipe.
- This key should be used if no more of this component is to be loaded
- The key is used when loading whole bales when the set weight has not been achieved.
- When the last feed component in the recipe stops, the pre-programmed **Mix after filling** will start.

Stop recipe filling

- Stops all filling and returns to the home screen without starting mixing.

3.3 Settings



Picture 24a



Picture 24b

Automatic counter-knife settings			
No	Time	In	Out
1.	Start	<input checked="" type="checkbox"/>	<input type="checkbox"/>
2.	0	<input checked="" type="checkbox"/>	<input type="checkbox"/>
3.	0	<input checked="" type="checkbox"/>	<input type="checkbox"/>
4.	0	<input checked="" type="checkbox"/>	<input type="checkbox"/>
5.	0	<input checked="" type="checkbox"/>	<input type="checkbox"/>
6.	0	<input checked="" type="checkbox"/>	<input type="checkbox"/>
7.	0	<input checked="" type="checkbox"/>	<input type="checkbox"/>
8.	0	<input checked="" type="checkbox"/>	<input type="checkbox"/>
9.	0	<input checked="" type="checkbox"/>	<input type="checkbox"/>
10.	0	<input checked="" type="checkbox"/>	<input type="checkbox"/>
11.	0	<input checked="" type="checkbox"/>	<input type="checkbox"/>
12.	Stop	<input type="checkbox"/>	<input checked="" type="checkbox"/>

Picture 24c

3.3.1 Settings for mixing

- **Mixing speed:** This adjusts the mixing speed according to your preference, limited by the maximum and minimum settings in the configuration screen. 100% corresponds to 100 Hz.
- **Automatic mixing speed –** Here you can set the maximum and minimum speed for the spindle. It will then operate automatically between these two levels.
- **Motor load for automatic speed -** The specified load of the motor is entered here as a percentage, for automatic speed during mixing and feeding.
- **Automatic reset of mixing time after loading:** When new material is loaded into the FeedMixer, the load will increase. You can choose to restart the mixing process from the beginning. A sound alert will be given.
- **Machines delivered by Kuhn have an option where mixing starts automatically.** This occurs when the weight exceeds the adjustable value.
- **Adjustment of counter-knife:** Activate / Deactivate

Automatic counter-knife settings

Here is determined how the counter-knives moves while mixing

- **Time - 0 = deactivated**
 - Minute from mixing start
 - Must be rising beyond the list
- **In / Out - Activate In or Out**

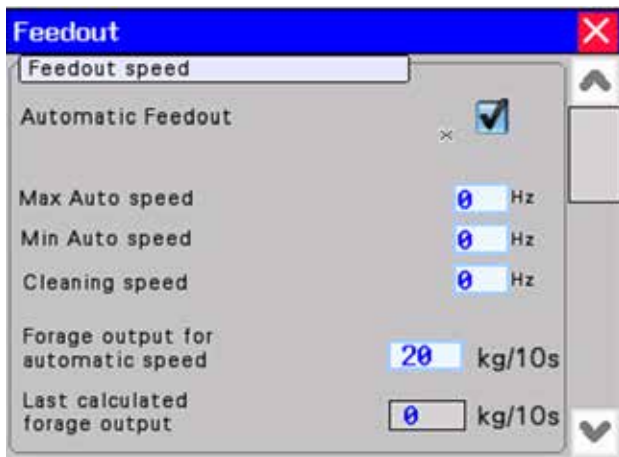

Picture 25

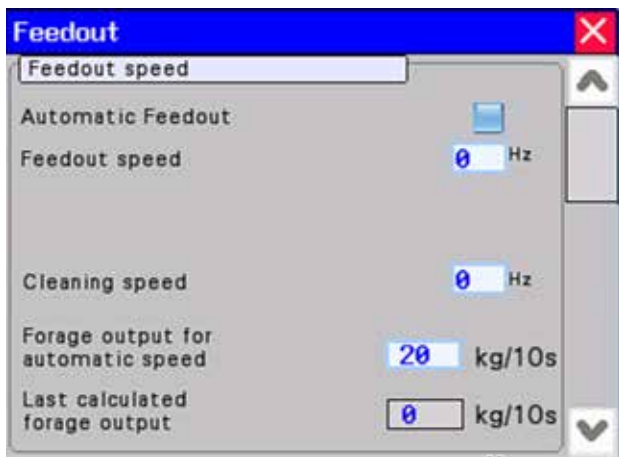

Picture 26



Picture 27

3.3.2 Settings for feedout

- **Feeding speed** – This adjusts the mixing speed according to your preference, limited by the max and min settings in the configuration screen. 100% corresponds to 100 Hz.

When FeedMixer is used together with FeedRobot or FeedBelt, the feedout speed must be set to **Medium** or Low. This is important in order to achieve an even feeding process.

- **Automatic feeding** – Here you can set the maximum and minimum speed for the spindle. It will then operate automatically between these two levels.

FeedMixer can automatically adjust the speed to dispense feed evenly.

- Set desired feed quantity in kg per 10 seconds.
- Last calculated feed quantity gives an indication of how much feed is expected to come out.
- This function is reserved for FeedBelt and other conveyors in the feed system.

Conveyor

It is possible to connect up to two conveyors to FeedMixer. The conveyors start each time discharging, and stop after the specified length of time when the auger has stopped.

- Specify stop delay (time for emptying the conveyors)

Level of empty containers

- When the mixer is almost empty, it is possible to set a function to clean the container.
- This can be set for the function to start at a fixed or automatic level.
- Select level
- Set weight limit for level.
- With automatic level, the function will start when weight reduction does not occur.
- Activate high speed clean. High speed clean causes the motor to operate at a high speed to eject any feed left on the screw
- Specify cleaning speed.
- Delay time – specify how long the screw needs to rotate after the function is complete.

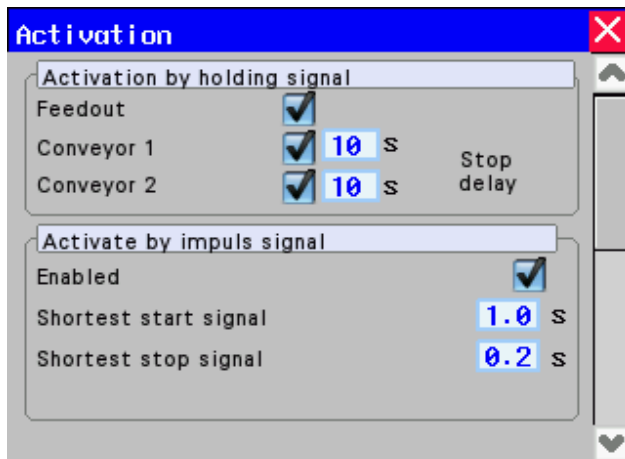

Picture 28

3.3.3 Settings for activation

Settings for remote control of feed dispensing on FeedMixer are configured here.

Activating the hold signal

FeedMixer can start dispensing feed in response to external signals issued by feed dispensing machines.

The start signal must be an active signal for the entire time the feed is being dispensed. A so-called hold signal.

When the signal is interrupted, feed dispensing stops.

Feeding and conveyors can be controlled independently of one another.

The only exception is the conveyors, which share a common start but stop at different times based on the desired delays.

External connections can be found in the electrical diagram on page 17.

Activation by pulse signal

FeedMixer can start the feedout process in response to machines with a pulse signal.

This means that FeedMixer starts with one signal and stops with another.

In order to prevent FeedMixer from starting in response to the wrong signal, the signals must have a minimum duration.

- Enable/disable pulse signal
- Select desired door

External connections can be found in the electrical diagram on page 17.

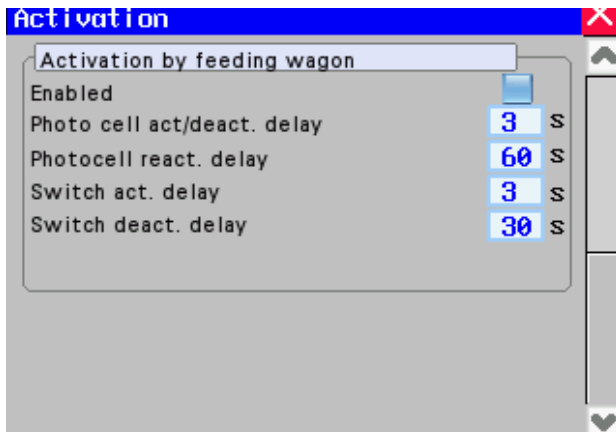

Picture 29

Activation with photocells and switches

When FeedMixer is used together with an external feed cart or machine, such as a FeedRobot or EasyFeed, FeedMixer can be started using a photocell and switch.

- **Activate/Deactivate the function**
- **Photocell act/deact. delay**

Photocell activating/diactivating delay – how long the photocell must have a stable signal before FeedMixer reacts.

- **Photocell react. delay**
Delay until reactivating of photocell – period of time after the end of the feedout process until the next feed may begin.
- **Switch act. delay**
Switch activation delay – how long FeedRobot must be in the switch position before the feedout process begins.
- **Switch deact. delay**
Switch deactivating delay – time to elapse before FeedMixer stops the feeding process if FeedRobot leaves the position.
- Select desired door

No	Name	No	Name
1.	kraftfor.	10.	9
2.	tst2	11.	10
3.	ii	12.	11
4.	yy	13.	12
5.	kk	14.	13
6.	5	15.	14
7.	6	16.	15
8.	7	17.	ny 6
9.	8	18.	ny 7

Picture 30

3.3.4 Settings for filling sources

The settings for the filling sources for recipe filling are found here.

- This screen shows the programmed and blank feed components/filling sources.
- Each feed component/filling source has its own settings.
- Select a filling source.
- To create a new one, press an empty line.
- The settings window for this component will open.

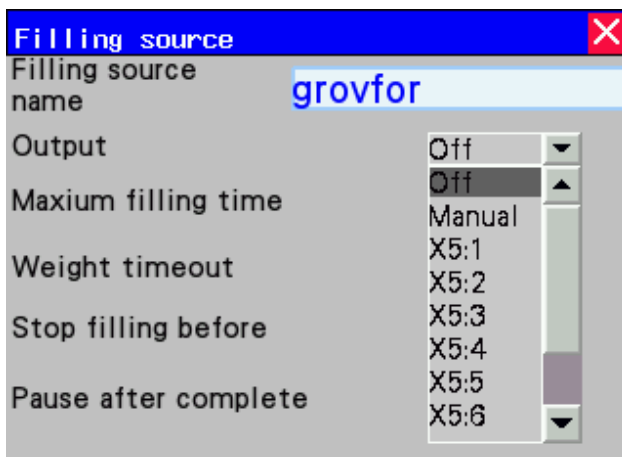

Picture 31

Filling source name

Enter the name of the filling source / feed component.

Output

Select whether the filling source will be manual or automatic (PLC A3:).

For automatic, separate electrical equipment must be connected to the electrical cabinet.

A3:02 refers to the circuit diagram.

Contact TKS for installation and connection.

Picture 32

No	Time	Recipe	En	No	Time	Recipe	En
1	00.00	0	<input checked="" type="checkbox"/>	8	00.00	0	<input checked="" type="checkbox"/>
2	00.00	0	<input checked="" type="checkbox"/>	9	00.00	0	<input checked="" type="checkbox"/>
3	00.00	0	<input checked="" type="checkbox"/>	10	00.00	0	<input checked="" type="checkbox"/>
4	00.00	0	<input checked="" type="checkbox"/>	11	00.00	0	<input checked="" type="checkbox"/>
5	00.00	0	<input checked="" type="checkbox"/>	12	00.00	0	<input checked="" type="checkbox"/>
6	00.00	0	<input checked="" type="checkbox"/>	13	00.00	0	<input checked="" type="checkbox"/>
7	00.00	0	<input checked="" type="checkbox"/>	14	00.00	0	<input checked="" type="checkbox"/>

Bilde 33

Bilde 34

Maximum filling time

Specifies how long the filling source will be active before it stops and moves on to the next filling source.

Weight timeout error

When the weight does not increase in this time, the filling source will stop and move on to the next filling source.

This parameter is only active for automatic filling sources.

Stop filling source before

Stops the filling source before the desired weight in the recipe is achieved. This is useful when manually loading bales. If you do not want overloading according to the recipe, but still want the automatic filling to move on to the next filling source without pressing the screen, set the value to e.g. 400 kg.

Pause after complete

Any additional waiting time can be set here before the next filling source is activated.

3.3.5 Automatic filling with schedule

The window shows settings for receptors associated with automatic filling. The function controls when the container will be filled.

- Activate by checking 'Act'.
- Select prescription number.

3.3.6 Automatic filling with weight

- Activate.
- Select prescription number.
- Specify weight limit for remaining feed in the container before filling starts.
- Specify delay before filling starts when weight limit is reached. The timer starts counting when the mixer stops.

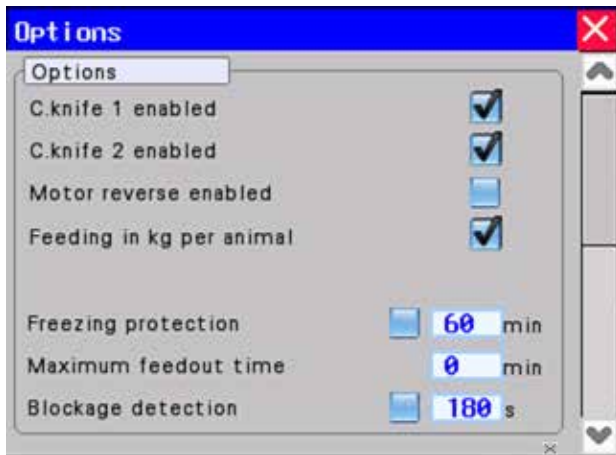

Picture 35

3.3.7 Settings options

Other settings and enabling/disabling of various functions can be performed here.

- **Counter knife 1 or 2**
 - Enable counter knives to allow FeedMixer to automatically move counter knives in position when mixing and retract them during the feedout process. When counter knives are disabled, they are stationary, and can be moved manually to the desired position.
- **Motor reverse enabled/disabled**
 - When mixing and feedout, the auger will rotate in reverse approximately a quarter revolution in order to loosen the feed before rotating in the working direction. This avoids overloading the motor on start-up. This function must be used when FeedMixer is loaded to the limit.

- **Freezing protection enabled/disabled**
 - During cold times of year, the feed may freeze to the auger and sides, and make it difficult for the auger to turn. You can prevent feed from freezing to surfaces by setting the auger to turn at defined intervals. Configure the desired interval.
- **Feeding in kg per animal.** By selecting this option, the number of animals will be set in the recipes. The weight in the table will then be multiplied by the number of animals.
- **Maximum feedout time**
 - To avoid overloading, the maximum feedout time is limited to 60 minutes. This time can be lowered as desired.

Blockage detection

If the weight of the content is not reduced during feedout, FeedMixer will stop after the set amount of time and sound an alarm. It is useful to use this function during automatic feedout when a connected machine may lead to blockages if it stops

- Activate with check box
- Configure the desired time before stop.
The time should not be less than 60 seconds.
- **Conveyor sensor**
 - When a conveyor is connected, this can be secured with a guard to prevent feed piling up if the conveyor stops.
- The function can be activated with connected sensor.

Shift to next screen with arrows to the right

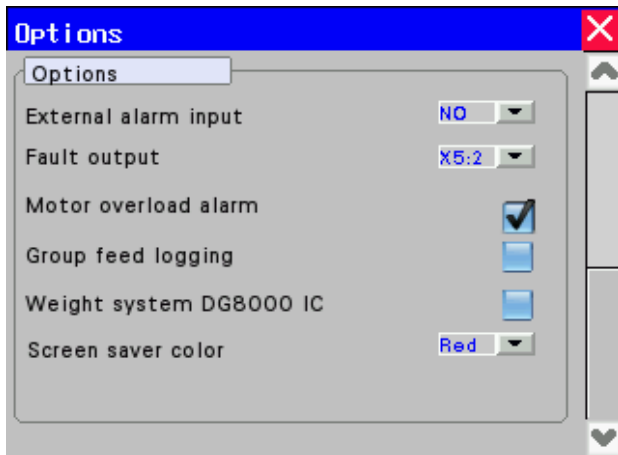

Picture 36

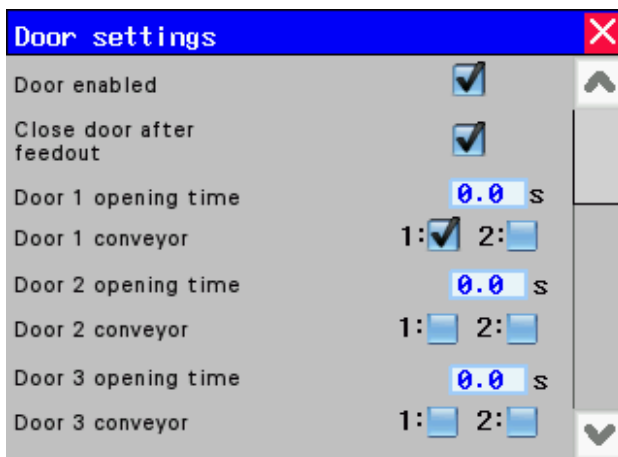

Picture 37



Picture 38

- **External alarm input Off / NO / NC**
 - Used when a connected machine may give an error message. This signal causes FeedMixer to stop. External connections can be found in the electrical diagram on page 17.
 - NO** - normally open signal
 - NC** - normally closed signal
- **Motor overload alarm - activate / disable**
 - emits an audio alarm when the load on the motor is too high. Do not load any feed until the alarm stops sounding.
- **Group feed logging**
 - Enables logging of data on feeding to different groups.

3.3.8 Door settings

The window shows door settings.

If there are several active doors, these are displayed.

If a door is opened and closed automatically, the door must be activated and an opening time must be set for each individual door.

- Enable door
- Close door after feedout - Activate / disable
- Door opening time
- Activate which conveyor, 1 or 2, will be connected to the relevant door.
- **Door enabled/disabled**
 - Enable the door to allow FeedMixer to automatically open/close the door when feeding. If disabled, the door must be controlled manually.
- **Door 1 opening time**
 - Configure the desired opening height for the door during automatic feedout. Enter opening time in seconds it takes to open the door to the level desired. Enter value 0 and door opens completely.

If you want feed to be dispensed evenly when the container is emptied, set the function – **Reduce door opening gradually.**

The door must be activated automatically.

Three steps can be set.

- Activate step.
- Specify weight at which the door will close
- Specify closing time

When high-speed cleaning is used, the door can be closed before cleaning starts. The weight limit for start is specified in the function **Level of empty containers** in the settings menu for feed dispensing

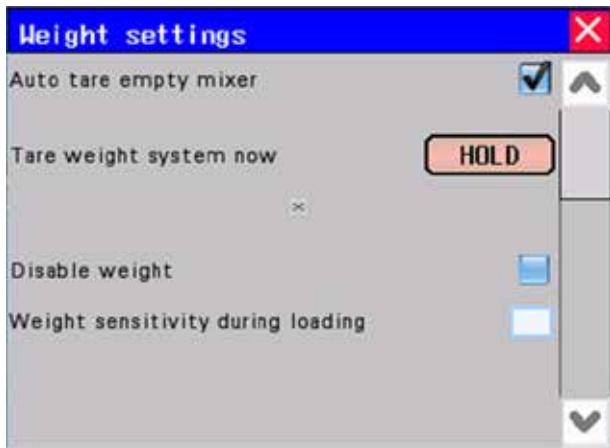

Picture 39

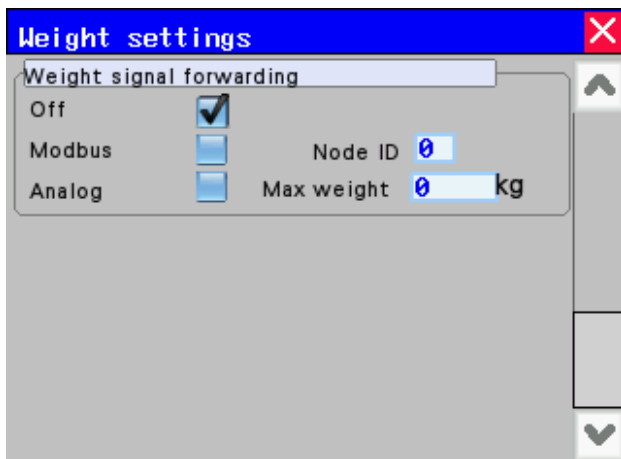

Picture 40

3.3.9 Weight settings

The window shows settings for the weighing system.

- Automatically resets weight when the mixer is empty. Activate/disable. The mixer is empty when the motor stops after any high-speed cleaning. Any feed residue in the container is then ignored.
- Now reset weight. Press **HOLD** for three seconds.
- **Deactivate weight.** Can be used in the event there is a delay in repairing the weighing system.
- **Weight sensitivity during loading.** Here, you can adjust the update speed of the weight during loading. A higher value results in faster but less accurate weight measurements.

Weight signal forwarding

Settings for forwarding signals to other systems.

Choose signal type

- Modbus
- Analogue

Set

- Node ID
- Max weight

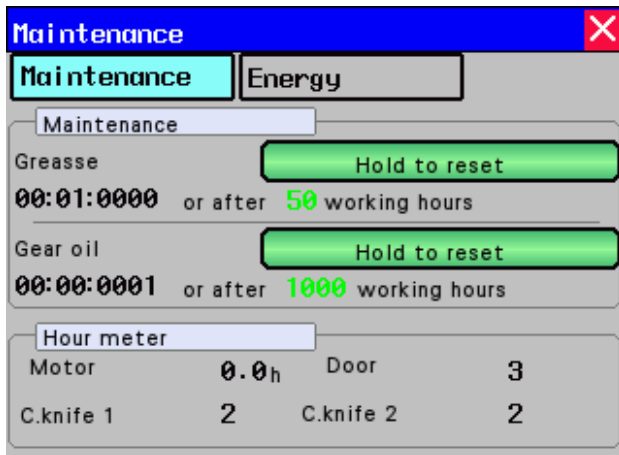

Picture 41

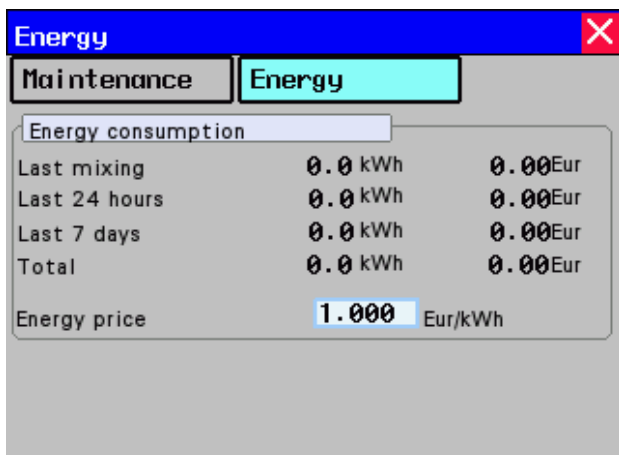

Picture 42

3.3.10 Maintenance/Energy

The window has two tabs for information on maintenance hours and energy consumption.

Maintenance

FeedMixer has a maintenance timer that generates a message on the screen when maintenance needs to be performed.

- Lubrication must be applied every month or every 50 hours.
- Gear oil must be changed every year or every 1,000 hours
- Maintenance must be carried out at the first possible opportunity.
- When maintenance is completed, the maintenance timer must be reset.
- Press **HOLD** to reset.

Hour meter

- Motor operating time
- Number of times door is opened
- Number of counter knife (Plate) movements in/out.

Energy consumption

FeeMixer calculates the energy consumption of the last mix, over the last 24 hours, the last seven days, and total consumption.

The calculation is rough, and the values is not accurate.

- Enter the price of energy in EUR/kWh. FeedMixer calculates the cost of consumption.

Time schedule									
No	Time	Kg	En	D	No	Time	Kg	En	D
1	00.00	0	<input type="checkbox"/>	0	9	00.00	0	<input type="checkbox"/>	0
2	00.00	0	<input type="checkbox"/>	0	10	00.00	0	<input type="checkbox"/>	0
3	00.00	0	<input type="checkbox"/>	0	11	00.00	0	<input checked="" type="checkbox"/>	0
4	00.00	0	<input type="checkbox"/>	0	12	02.00	0	<input checked="" type="checkbox"/>	0
5	00.00	0	<input type="checkbox"/>	0	13	04.00	0	<input type="checkbox"/>	0
6	00.00	0	<input type="checkbox"/>	0	14	06.00	0	<input type="checkbox"/>	0
7	00.00	0	<input type="checkbox"/>	0	15	08.00	0	<input type="checkbox"/>	0
8	00.00	0	<input type="checkbox"/>	0	16	10.00	0	<input type="checkbox"/>	0

Picture 43

3.3.11 Feedout timer

FeedMixer can be set to dispense feed automatically according to a time schedule. Up to 16 different times can be configured individually. It is appropriate to use this function if a feed dispensing machine does not have a separate feedout timer.

- **Time** - set the desired feed dispensing time.
- **Kg** - specify the feed quantity for each time
- **En** - enable this feed dispensing with check box.
- **D** - specify the door to be used.
- Press the figure to switch between door 1, 2 or 3.

When at least one feedout session is enabled, a green lamp with the text **AUTO** will be displayed at the top of the Home screen.

When automatic feed dispensing is used, the feed must still be mixed manually. Mixing must be performed at a time between two automatic feed dispensing sessions. If FeedMixer is empty when dispensing, FeedMixer will stop and an alert will appear on the screen.



Picture 44

3.3.12 Language

Select display language

3.4 Alarms



Picture 45

FeedMixer stops when an alarm is triggered. The screen shows the alarm window and which alarm was triggered.

The window can be closed by pressing the X in the upper right-hand corner.

A yellow symbol displays on the Home screen.

Touch the symbol to open the alarm window again.

- Reset the alarms using the **Reset alarm** - key
- If the error has not been corrected, the alarm will trigger again shortly

The following error messages may display:

- Frequency inverter fault
- Conveyor fault
- Door fault
- Limit switch fault, counter knife 1 (Plate 1)
- Limit switch fault, counter knife 2 (Plate 2)
- Feedout process fault
- External alarm input
- Perform maintenance
- Error on logging

3.5 Doors 2 and 3 (Option)

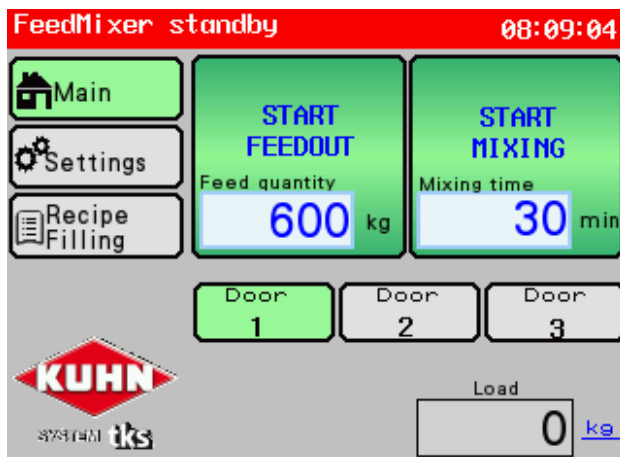

Picture 46

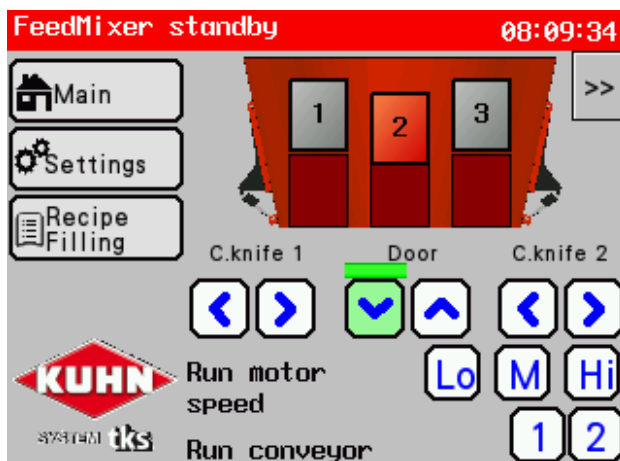

Picture 47

FeedMixer can be equipped with the operation of up to three doors. Dispensing with multiple doors is appropriate where several feed dispensing machines are connected. All the doors can be controlled automatically from the connected machine or they can be operated manually. Door settings, see **chap. 3.3.7**

Feedout

Select the desired door before feedout. Press the desired door: 1, 2, 3. Then start the feedout. When feedout to another door is desired, the door that was last activated closes automatically and the desired door opens before the feedout starts.

Manual control

First select the desired door on the screen. The door in red is active. Open and close the door using the up and down arrow keys.

See section 3.2.5 for more information.

4 Troubleshooting

Fault	Causes	Procedure – error correction
Auger does not rotate	<ul style="list-style-type: none"> • <i>The shear bolt in the bolt-connection in front of the planet gear has sheared.</i> 	<ul style="list-style-type: none"> • <i>Replace the shear bolt.</i>
Weight system, door or conveyor belt not working	<ul style="list-style-type: none"> • <i>Voltage too high.</i> • <i>Power cut.</i> 	<ul style="list-style-type: none"> • <i>Check the fuses.</i> • <i>Turn off the mains supply for 30 seconds. Motor, door and counter knives will be reset automatically.</i>
Scales are showing incorrect values Scales are not working	<ul style="list-style-type: none"> • <i>The settings on the load cell amplifier are incorrect.</i> 	<ul style="list-style-type: none"> • <i>The load cell amplifier must be configured correctly.</i>
	<ul style="list-style-type: none"> • <i>Auger connections on the scales' components have come loose.</i> 	<ul style="list-style-type: none"> • <i>Retighten the augerconnections.</i>
	<ul style="list-style-type: none"> • <i>The switch is moist.</i> • <i>Insufficient contact in cables.</i> 	<ul style="list-style-type: none"> • <i>Clean and dry the switch (do not use contact spray).</i>
Alarm! Door fault	<ul style="list-style-type: none"> • <i>El. actuator does not reach top or bottom endpoint-within 30 seconds.</i> • <i>Silage in channel to door.</i> 	<ul style="list-style-type: none"> • <i>Clean the outlet.</i> • <i>Check clearance in the slot of the door.</i>
Alarm! Fault on limit switch for the counter knives	<ul style="list-style-type: none"> • <i>Both of the limit switches in the el. actuator give a signal.</i> 	<ul style="list-style-type: none"> • <i>Check the cables for faults.</i>
Alarm! Frequency inverter fault	<ul style="list-style-type: none"> • <i>Power supply to the motor.</i> • <i>Overload/overheating on motor.</i> 	<ul style="list-style-type: none"> • <i>Check the power supply.</i> • <i>Wait until the engine has cooled.</i> • <i>Press Reset alarms to reset the frequency inverter</i>
Alarm! Conveyor fault	<ul style="list-style-type: none"> • <i>Power supply to the motor.</i> • <i>Overload on motor.</i> 	<ul style="list-style-type: none"> • <i>Check the conveyor.</i> • <i>Enable motor protection.</i>
Alarm! Feed feeding fault	<ul style="list-style-type: none"> • <i>When there is no reduction in weight during the discharging process.</i> 	<ul style="list-style-type: none"> • <i>Check the door outlet.</i>
Alarm! External alarm input	<ul style="list-style-type: none"> • <i>Fault in connected machine.</i> 	<ul style="list-style-type: none"> • <i>Check connected machine.</i>

TKS is a family owned company
with a strong brand name.
We are providing our customers with a
unique and complete range and high
quality products.

www.tks-agri.no



TKS Agri AS,
Kvernelandsvegen 100
N-4355 Kverneland
Norway

e-post post@tk-as.no
Phone +47 51 77 05 00