

T.Kverneland & Sønner AS  
 Kvernelandsvegen 100  
 4355 KVERNELAND

AGRI

0	10.05.2021	alexanderk		REVISION
				0
REV.	DATE	NAME	CHANGES	SCHEME
				03

CONTRACT: 51770500

LOCATION: +S1

230V

User data 1

User data 2

SOLIDWORKS Electrical



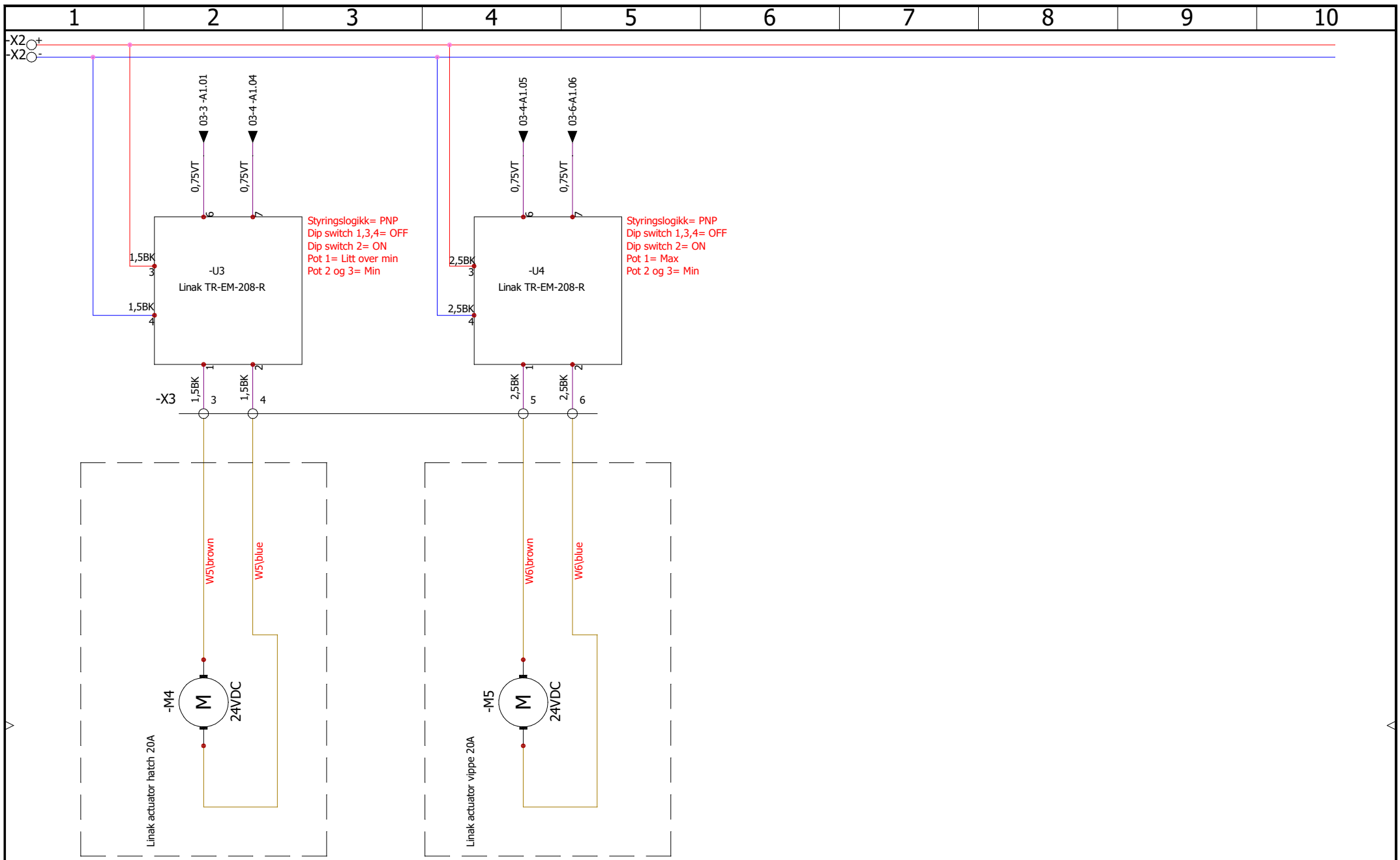

T.Kverneland & Sønner AS  
 Kvernelandsvegen 100  
 4355 KVERNELAND

AGRI

0	10.05.2021	alexanderk		REVISION
				0
REV.	DATE	NAME	CHANGES	SCHEME
				05

CONTRACT: 51770500

LOCATION: +S1 230V

User data 1

User data 2

SOLIDWORKS Electrical

- S2=Nødstop
- S3= Tillat kjør luke  
-S3.1=Set pot.verdi
- R2=Potmeter
- S4=Blanding&utmating  
-S4.1=Utmating
- S5=Start auto  
-S5.1=Start manuell
- S6= Lukke luke  
-S6.1= Åpne luke

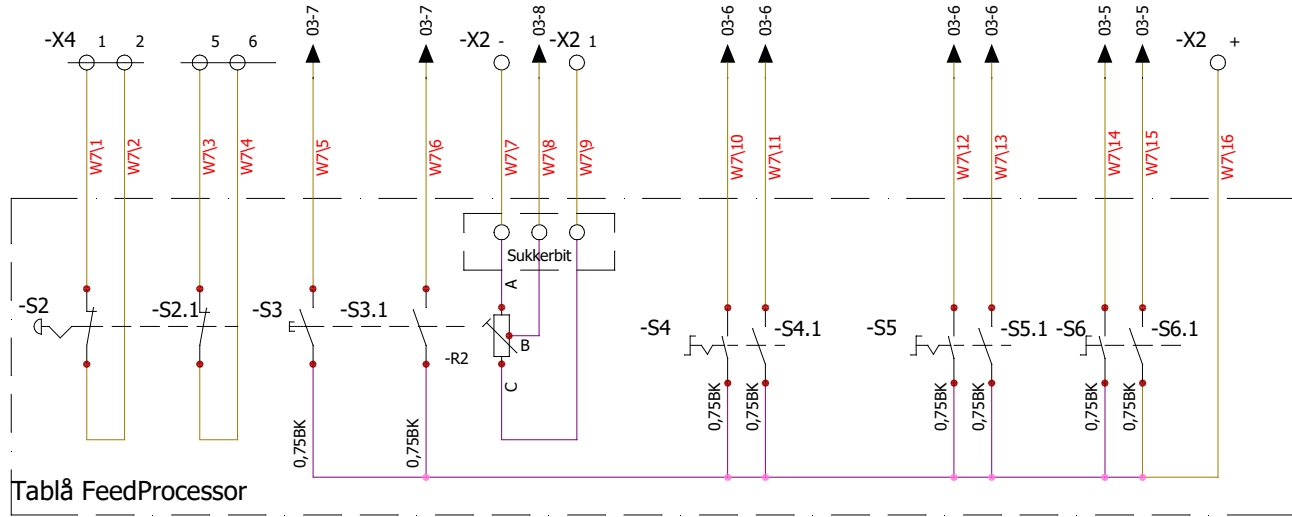

T.Kverneland & Sønner AS  
Kvernelandsvegen 100  
4355 KVERNÅLAND

AGRI

0	10.05.2021	alexanderk		REVISION
				0
REV.	DATE	NAME	CHANGES	SCHEME
User data 1			User data 2	06

CONTRACT: 51770500

LOCATION: +S1

230V

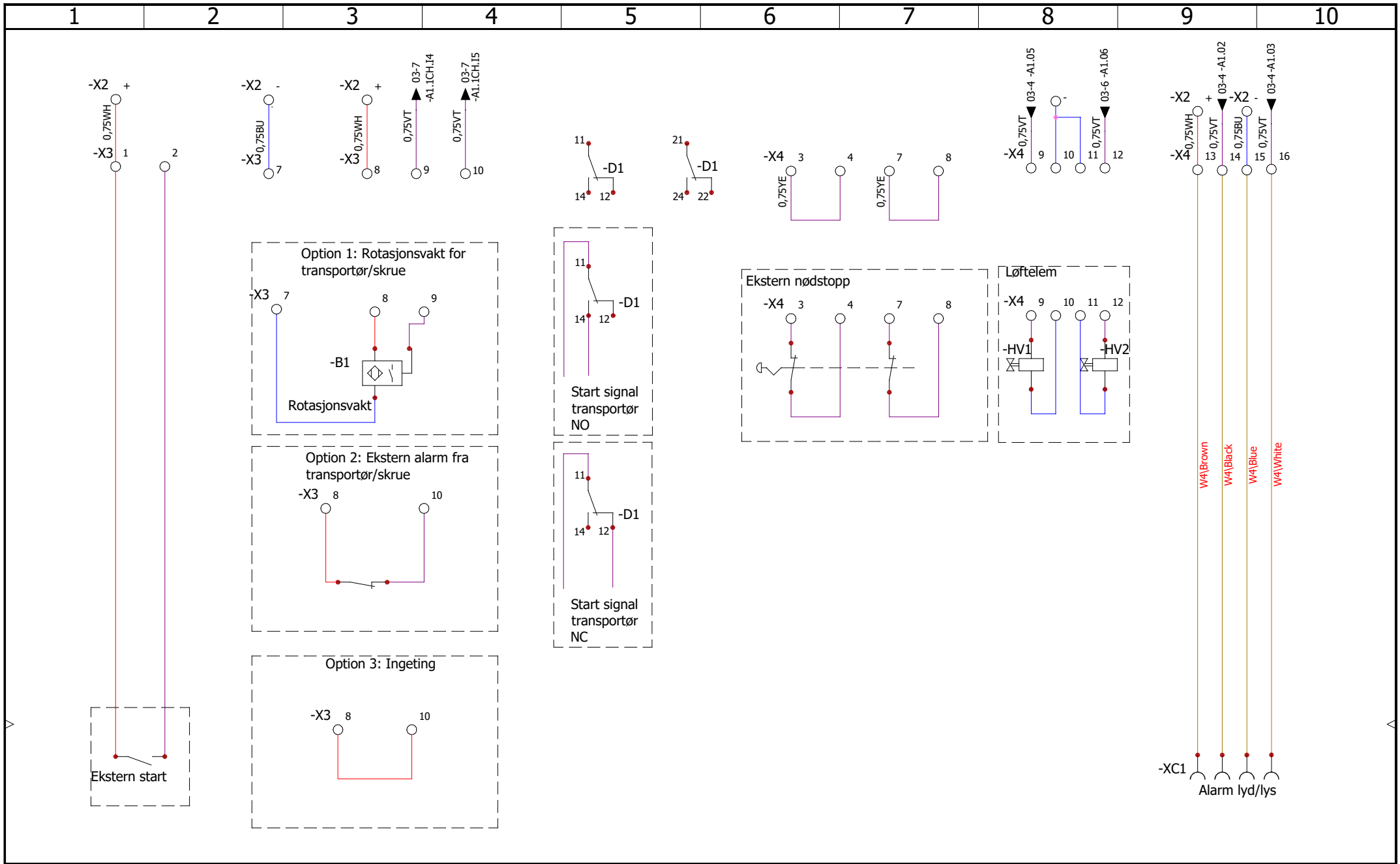

T.Kverneland & Sønner AS  
 Kvernelandsvegen 100  
 4355 KVERNÅLAND

AGRI

0	10.05.2021	alexanderk		REVISION
				0
REV.	DATE	NAME	CHANGES	SCHEME
				07

CONTRACT: 51770500

LOCATION: +S1

230V

User data 1

User data 2

SOLIDWORKS Electrical

=FP1+S1-A1

<u>O</u> :	00		Omron	CP1L-M30DR-D	=FP1+S1-A1	Nødstopp reset
<u>O</u> :	01		Omron	CP1L-M30DR-D	=FP1+S1-A1	Åpne luke
<u>O</u> :	02		Omron	CP1L-M30DR-D	=FP1+S1-A1	Alarm lys
<u>O</u> :	03		Omron	CP1L-M30DR-D	=FP1+S1-A1	Alarm lyd
<u>O</u> :	04		Omron	CP1L-M30DR-D	=FP1+S1-A1	Lukke luke
<u>O</u> :	05		Omron	CP1L-M30DR-D	=FP1+S1-A1	Kjør vippe opp/magasin frem
<u>O</u> :	06		Omron	CP1L-M30DR-D	=FP1+S1-A1	Kjør vippe ned/magasin bak
<u>O</u> :	07		Omron	CP1L-M30DR-D	=FP1+S1-A1	Kjør belter/skruer
<u>I</u> :	10		Omron	CP1L-M30DR-D	=FP1+S1-A1	Nødstop OK
<u>I</u> :	10		Omron	CP1L-M30DR-D	=FP1+S1-A1	Start auto
<u>I</u> :	11		Omron	CP1L-M30DR-D	=FP1+S1-A1	Start manuell
<u>I</u> :	I10		Omron	CP1L-M30DR-D	=FP1+S1-A1	Blanding&utmating
<u>I</u> :	I11		Omron	CP1L-M30DR-D	=FP1+S1-A1	Utmating
<u>I</u> :	12		Omron	CP1L-M30DR-D	=FP1+S1-A1	Set pot.verdi
<u>I</u> :	13		Omron	CP1L-M30DR-D	=FP1+S1-A1	Knapp kjør luke
<u>I</u> :	14		Omron	CP1L-M30DR-D	=FP1+S1-A1	Rotasjonsvakt
<u>I</u> :	15		Omron	CP1L-M30DR-D	=FP1+S1-A1	Alarm inngang
<u>I</u> :	16		Omron	CP1L-M30DR-D	=FP1+S1-A1	Vippe opp/magasin fram
<u>I</u> :	17		Omron	CP1L-M30DR-D	=FP1+S1-A1	Vippe ned/magasin reverse
<u>I</u> :	19		Omron	CP1L-M30DR-D	=FP1+S1-A1	Ekstern start

T.Kvernalund & Sønner AS  
Kvernalandsvegen 100  
4355 KVERNÅLAND

AGRI

0	10.05.2021	alexanderk		REVISION
				0
REV.	DATE	NAME	CHANGES	SCHEME
				08
User data 1			User data 2	

CONTRACT: 51770500

LOCATION: +S1

230V